

# AMC FPGA Carrier

## AMC510



### KEY FEATURES

- AMC FPGA carrier to add customize mezzanines modules
- Clock in/out
- Trig in/out
- Sync in/out
- AMC Ports 0-1 and 4-11 are routed to FPGA (protocols such as PCIe, SRIO, XAUI, etc. are FPGA programmable)
- Xilinx Virtex-5 FPGA in FF1136 package
- AMC FCLK, CLKA, CLKB, CLKC and CLKD are routed
- On board PLL for buffering/multiplying and jitter cleaner
- Option for QDR-II
- RoHS compliant

The AMC510 is an AMC FPGA Carrier so that it would allow custom mezzanine to be developed for different end applications. The module is compliant to the AMC.1, AMC.2 and/or AMC.4 specification. The unit has an on-board, re-configurable FPGA which interfaces directly to the AMC Ports 0-1, 4-11, FCLK, ACLK, BCLK, CCLK, and DCLK. The FPGA has an interface to the QDR-II memory (36 and 72-bit wide). This allows for large buffer sizes to be stored during processing as well as for queuing the data to the host.

The AMC510 allows for external clocking as well as internal clocking. The clock goes through an on-board PLL for buffering/multiplying and jitter cleaner.

Trig in/out, Clock in/out and Sync in/out have an SMB connector in the front.

VadaTech can modify this product to meet special customer requirements without NRE (minimum order placement is required).

**AdvancedMC™**

## SPECIFICATIONS

Architecture		
Physical	Dimensions	Double-width, Full-Height
		Width: 5.85in. (148.5 mm)
		Depth: 7.11 in. (180.6 mm)
Type	AMC FPGA Carrier	Xilinx FGPA Virtex-5 Devices
		PLL multiplier/divider with jitter cleaner
		External clock with Trig in/out
		QDR-II
Standards		
AMC	Type	AMC.1, AMC.2, and AMC.4 (FPGA programmable)
Module Management	IPMI	IPMI Version 2.0
PCIe	Lanes	x4 or x8
XAUI	Lanes	Dual port XAUI
Aurora/SRIO	Lanes	x4
Ethernet	GbE	1000-BaseBX
Configuration		
Power	AMC510	Carrier is 10W without the Mezzanine
Environmental	Temperature	Operating Temperature: 0° to 65° C (Air flow requirement is to be greater than 400 LFM)
		Storage Temperature: -40° to +90° C
	Vibration	1G, 5-500Hz each axis
	Shock	30Gs each axis
Front Panel	Relative Humidity	5 to 95 percent, non-condensing
	Interface Connectors	Three SMB style
	LEDs	IPMI Management Control
		12 user defined LED
Mechanical	Hot Swap Ejector Handle	
Software Support	Operating Systems	Linux, Windows, Solaris and VxWorks
Other		
MTBF	MIL Handbook 217-F > TBD.	
Certifications	Designed to meet FCC, CE and UL certifications where applicable	
Standards	VadaTech is certified to both the ISO9001:2000 and AS9100B:2004 standards	
Compliance	RoHS and NEBS	
Warranty	Two (2) years.	
Trademarks and Logos	The VadaTech logo is a registered trademark of VadaTech, Inc. Other registered trademarks are the property of their respective owners. AdvancedMC™ and the AdvancedTCA™ logo are trademarks of the PCI Industrial Computers Manufacturers Group. All rights reserved. Specification subject to change without notice.	

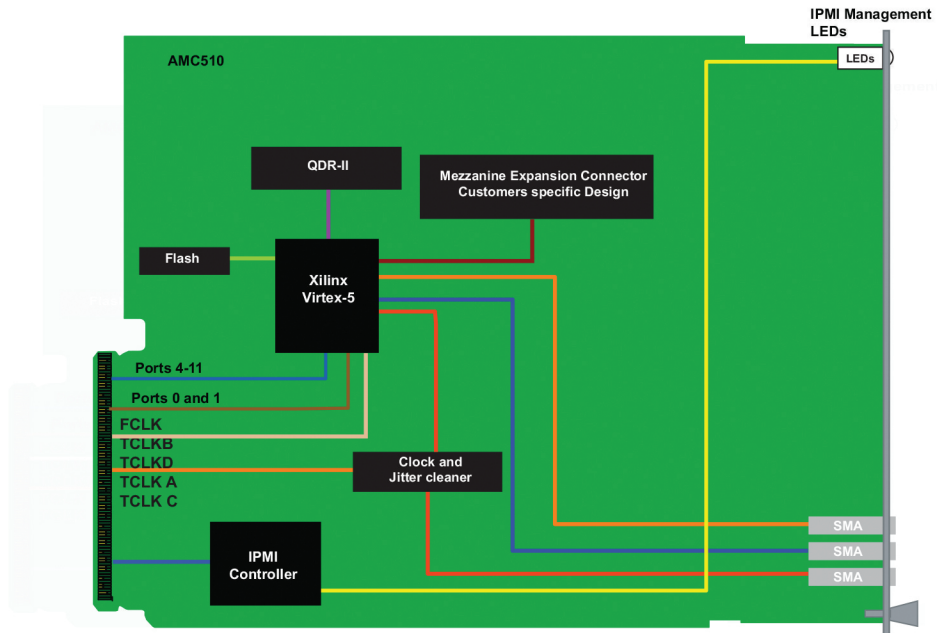
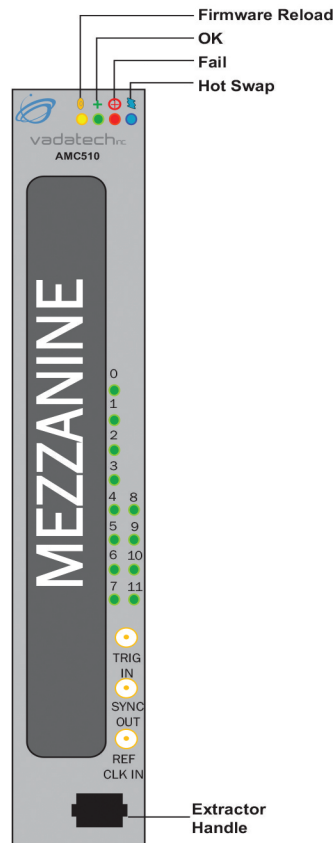

FIGURE 1. AMC510 Functional Block Diagram

FIGURE 2. AMC510 Functional Block Diagram



## ORDERING OPTIONS

### AMC510 - A0C - DE0 - 00J

#### A = QDR-II Memory

- 0 = None
- 1 = 2 x 36 (single chip)
- 2 = 2 x 72 (two chips)
- 3 = Reserved

#### C = Front Panel

- 1 = Reserved
- 2 = Reserved
- 3 = Full-Height

#### D = FPGA

- 1 = Reserved
- 2= XC5VSX95T
- 3= XC5VLX110T
- 4= XC5VLX155T
- 5= Reserved
- 6= Reserved
- 7= Reserved

#### E = FPGA SPEED

- 1 = Low
- 2 = High

#### J = Conformal Coating

- 0 = None
- 1 = Humiseal 1A33 Polyurethane
- 2 = Humiseal 1B31 Acrylic

